

| ITEM | DESCRIPTION | PART NO. | QTY |
|------|---|-------------------|-----|
| 1 | STYLE HANDLE | Z87015 | 2 |
| 2 | BUSHING | P87007 | 2 |
| 3 | STYLE HANDLE BASE | Z87018 | 2 |
| 4 | HANDLE ADAPTER | P87003 | 2 |
| 5 | CARTRIDGE 1/2" VALVE 90 DEGREE LEFT TURN | CB87082 | 1 |
| 6 | SEAL 37X32X2.5 | P87004 | 2 |
| 7 | WASHER 28.8X41.5X2.2 | B87024 | 2 |
| 8 | SETTING SCREW M3 X 8 | S87001 | 2 |
| 9 | SPRING WASHER | B87090 | 2 |
| 10 | DECK ADAPTER | B87023 | 2 |
| 11 | WASHER 28 X 42 | P87005 | 2 |
| 12 | BOLT M8 | B87022 | 1 |
| 13 | CARTRIDGE 1/2" VALVE 90 DEGREE RIGHT TURN | CB87083 | 1 |
| 14 | FIXATION NUT M28X1.5 | B87025 | 2 |
| 15 | SCREW M5 X 0.8 | S87002 | 4 |
| 16 | CONNECTION HOSE 1/2" BY M10 | C087003 | 2 |
| 17 | FIXATION NUT M8 | B87028 | 1 |
| 18 | DIVERTER ROD | B87027 | 1 |
| 19 | STYLE SPOUT WIDE SPREAD | B87062 | 1 |
| 20 | STYLE LIFT KNOB WIDE SPREAD | Z87019 | 1 |
| 21 | AERATORS MS6035 1.5GPM M20X1 | C087013 | 1 |
| 22 | SEAL 41X36X2.5 | P87009 | 1 |
| 23 | FIXATION PLATE | C087002 | 1 |
| 24 | POPOP WASTE | CB87075 | 1 |
| 25 | | DRY_BAG | 1 |
| 26 | | PACKAGING | 1 |
| 27 | | INSTRUCTION_SHEET | 1 |

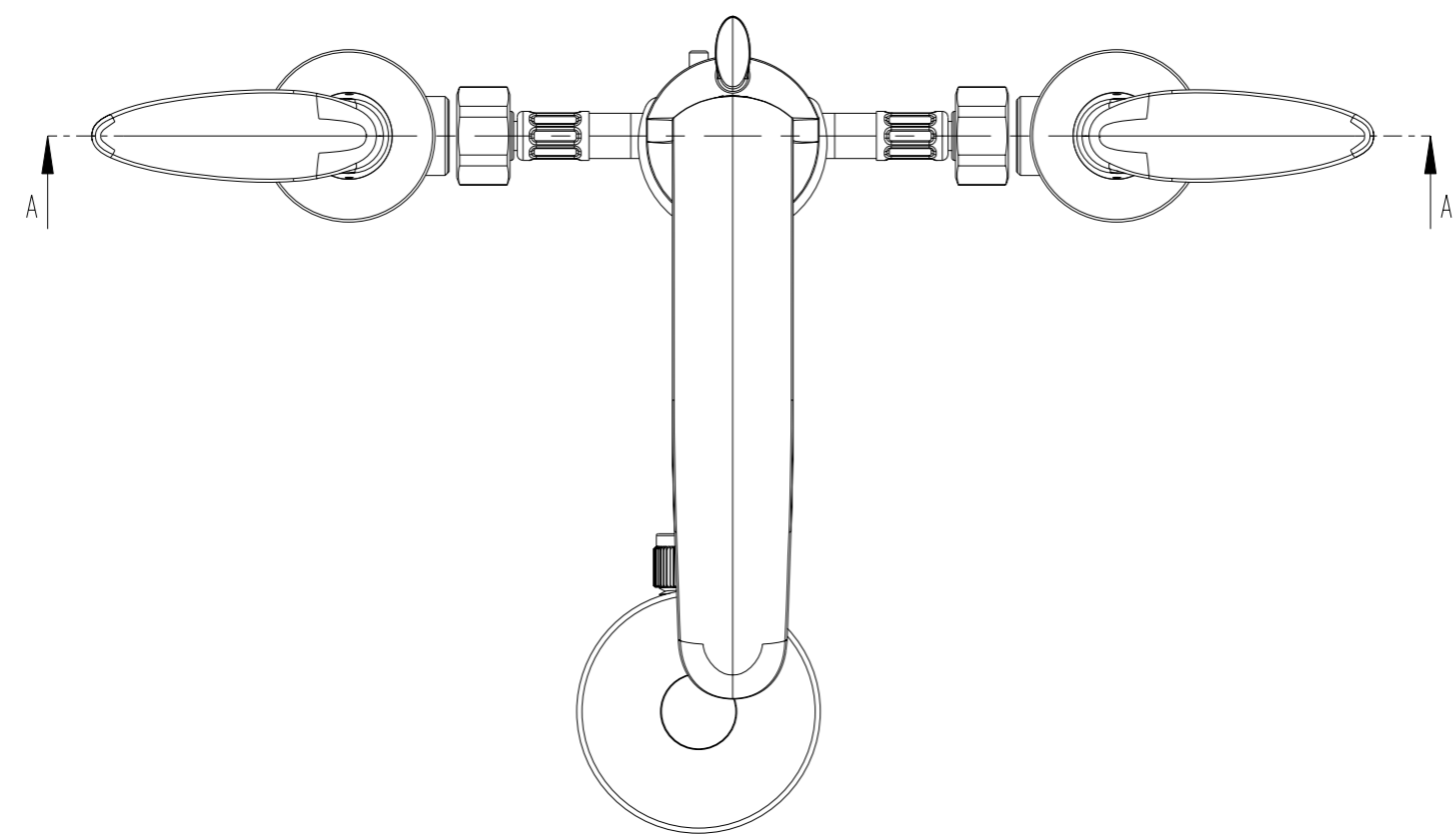

STYLE widespread

Finish: chrome
Article number: 1009 1 00 1

