

SCALE 3:10

| ITEM | DESCRIPTION | PART NO. | QTY |
|------|------------------------------|-------------------|-----|
| 1 | AERATORS MS6035 1.5GPM M20X1 | C087013 | 1 |
| 2 | SET SCREW M5 | S87008 | 1 |
| 3 | TOP CAP | B87075 | 1 |
| 4 | LOCK RING | B87067 | 1 |
| 5 | CARTRIDGE (K-25 PVD+) | C087019 | 1 |
| 6 | CARTRIDGE SEAT | B87071 | 1 |
| 7 | O RING \varnothing 22X2 | P87063 | 2 |
| 8 | STYLE SPOUT BODY | B87080 | 1 |
| 9 | SEAL 41X36X2.5 | P87009 | 1 |
| 10 | WASHER 32.8X48X2.2 | B87097 | 1 |
| 11 | NUT M32X1.5 | B87094 | 1 |
| 12 | SHANK | B87082 | 1 |
| 13 | CONNECTION HOSE | C087009 | 2 |
| 14 | STYLE HANDLE | Z87106 | 1 |
| 15 | COVER | P87025 | 1 |
| 16 | WASHER 32 X 48 | P87034 | 1 |
| 17 | SCREW M5 X 0.8 | S87010 | 2 |
| 18 | | DRY_BAG | 1 |
| 19 | | PACKAGING | 1 |
| 20 | | INSTRUCTION_SHEET | 1 |

Style one-hole single-lever vessel mixer

Finish: chrome
Article number: 1028 1 00 2

Finish: brushed nickel
Article number: 1028 1 20 2

in2aqua

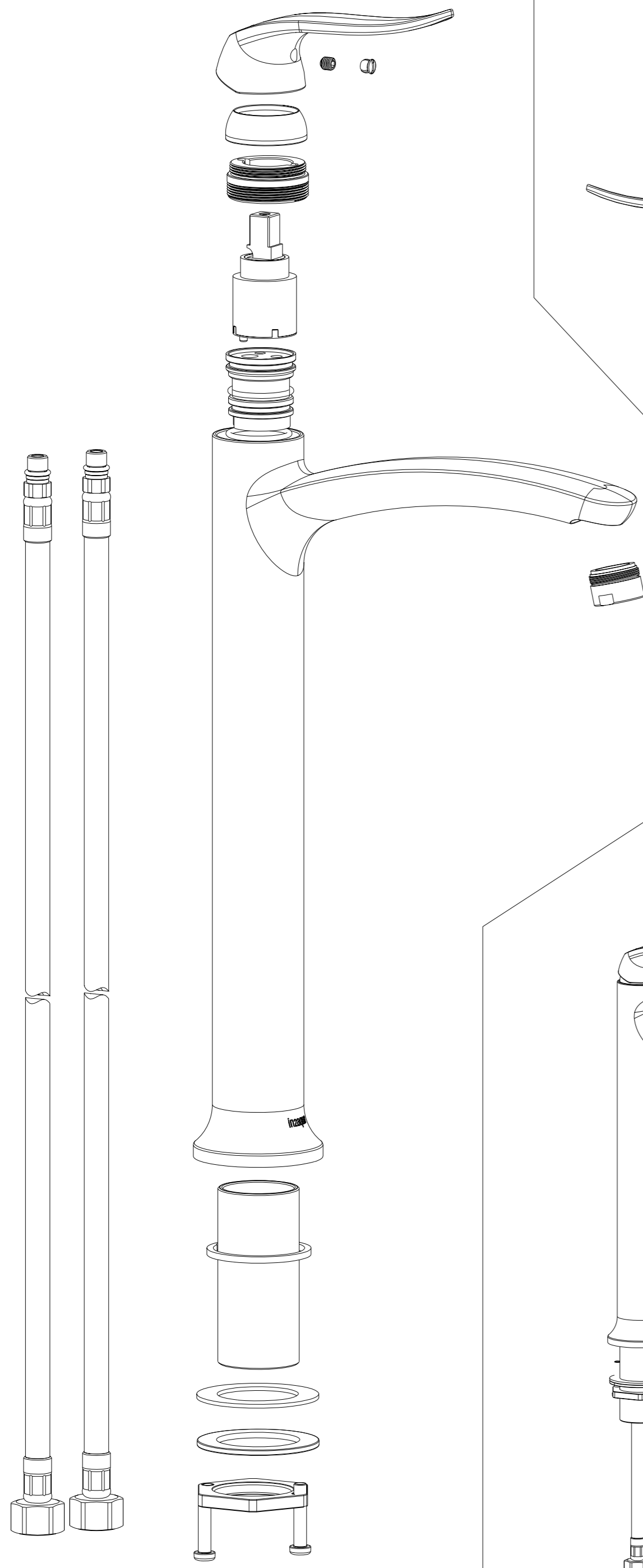

SCALE 3:5

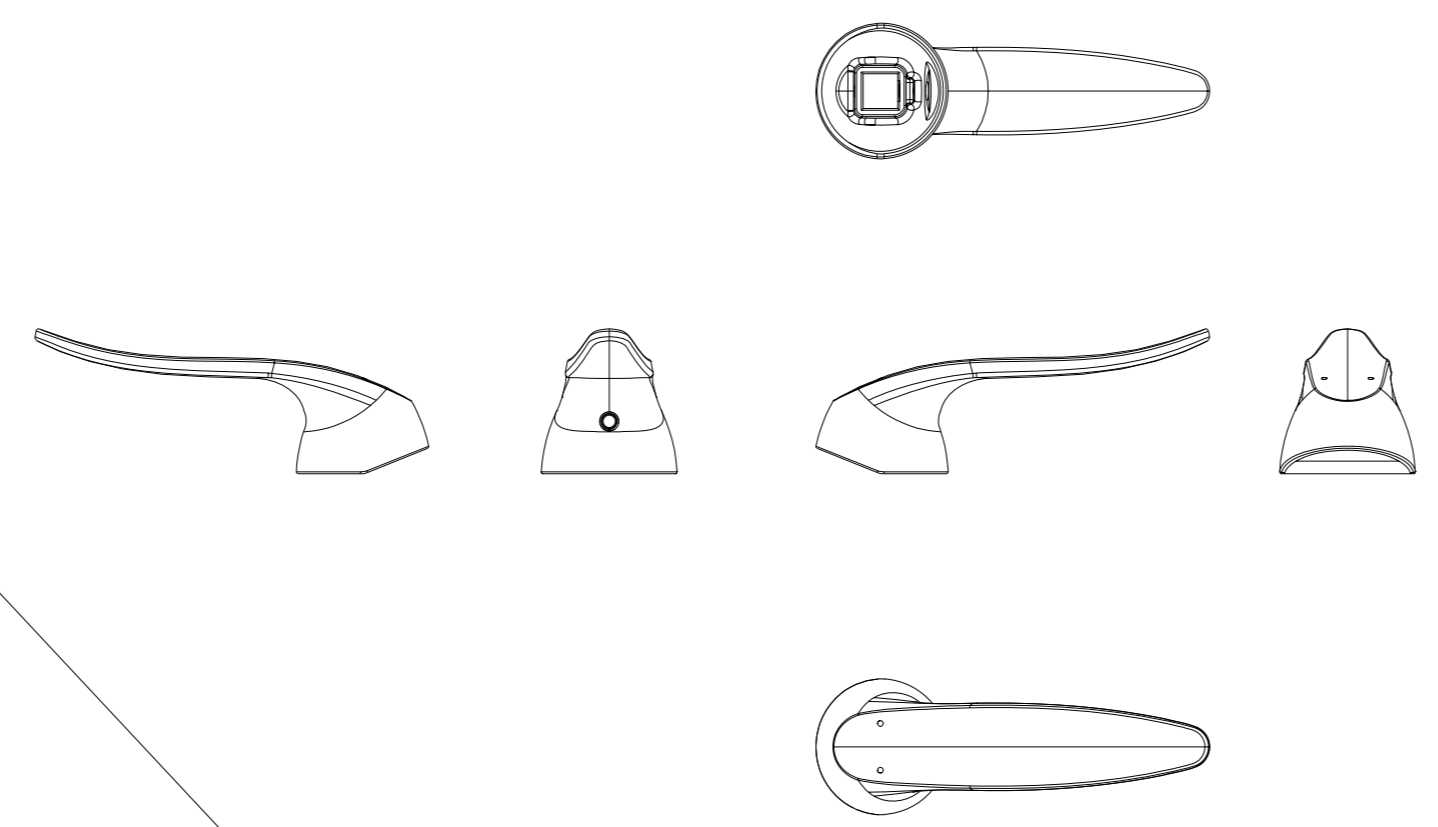

SCALE 1:2

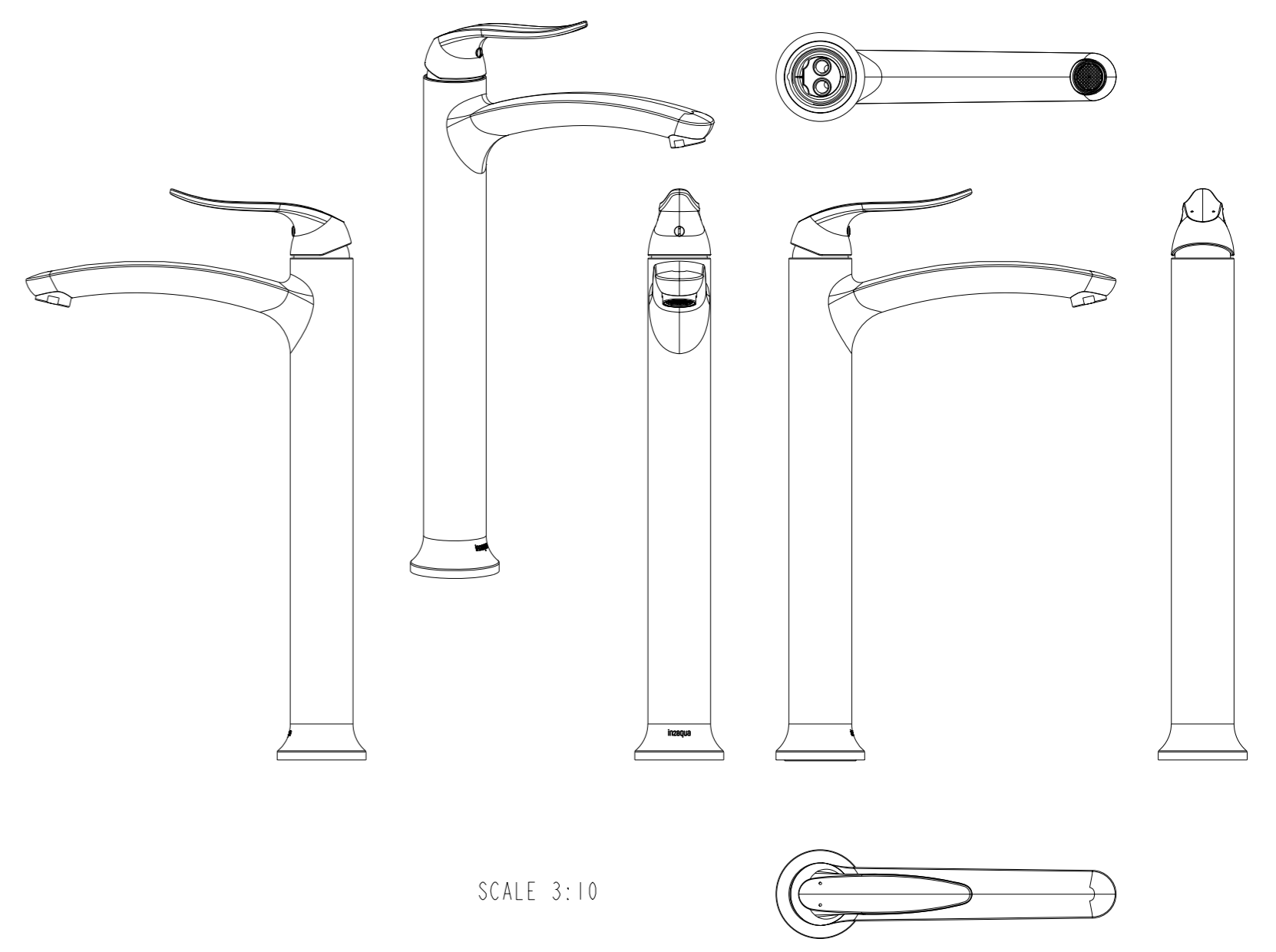
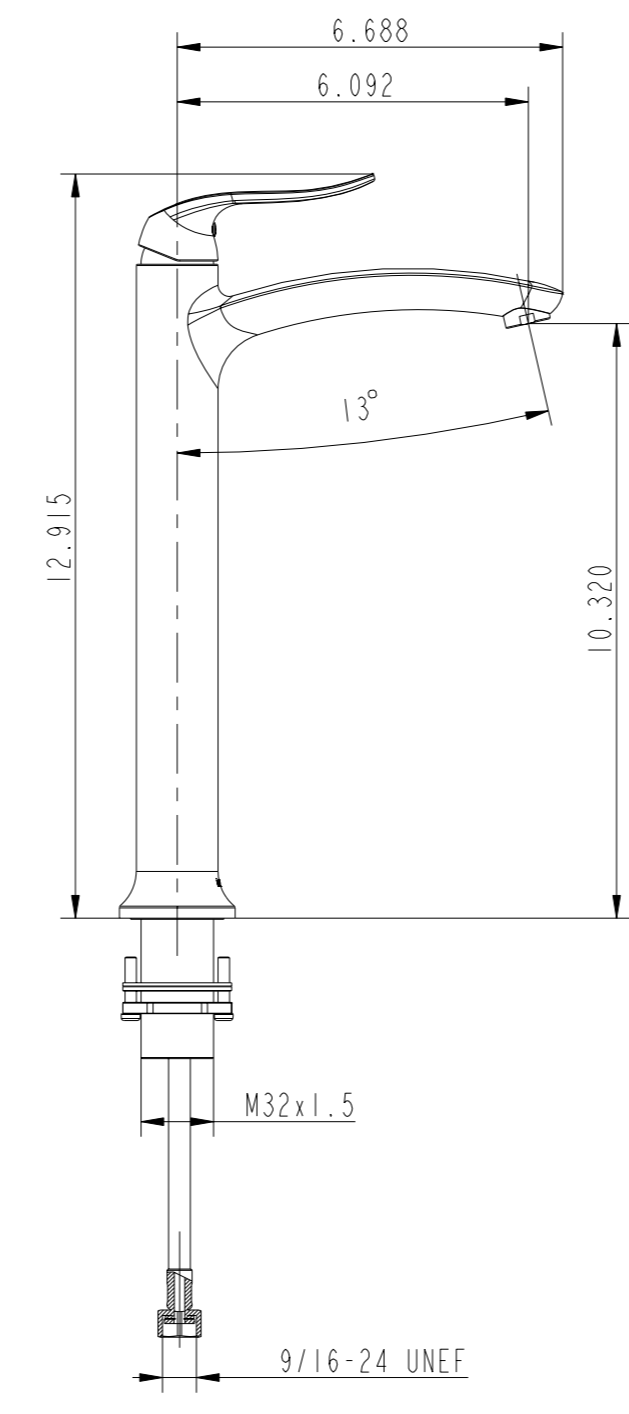
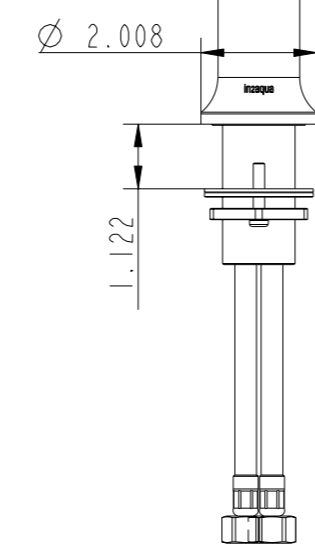
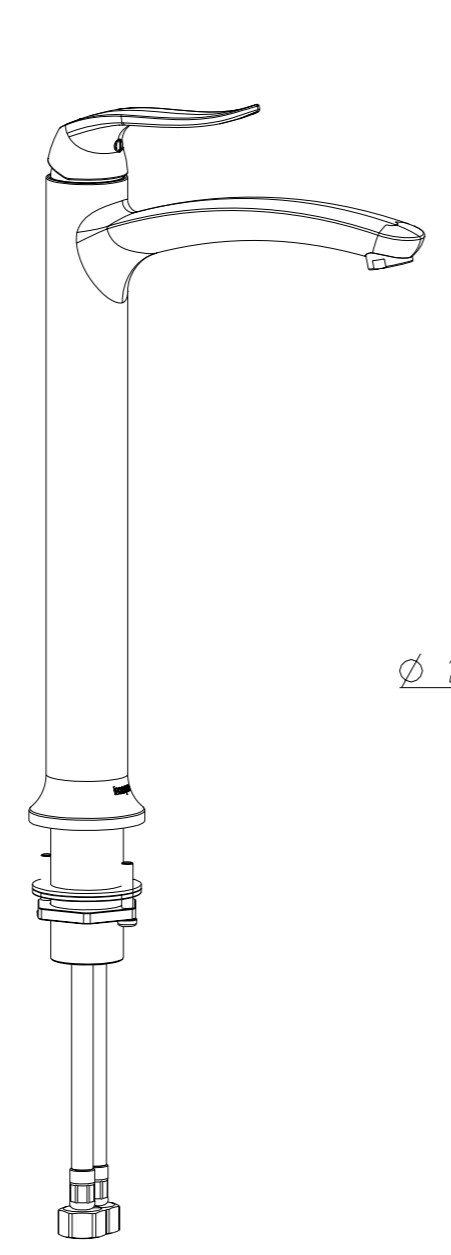

SCALE 3:10

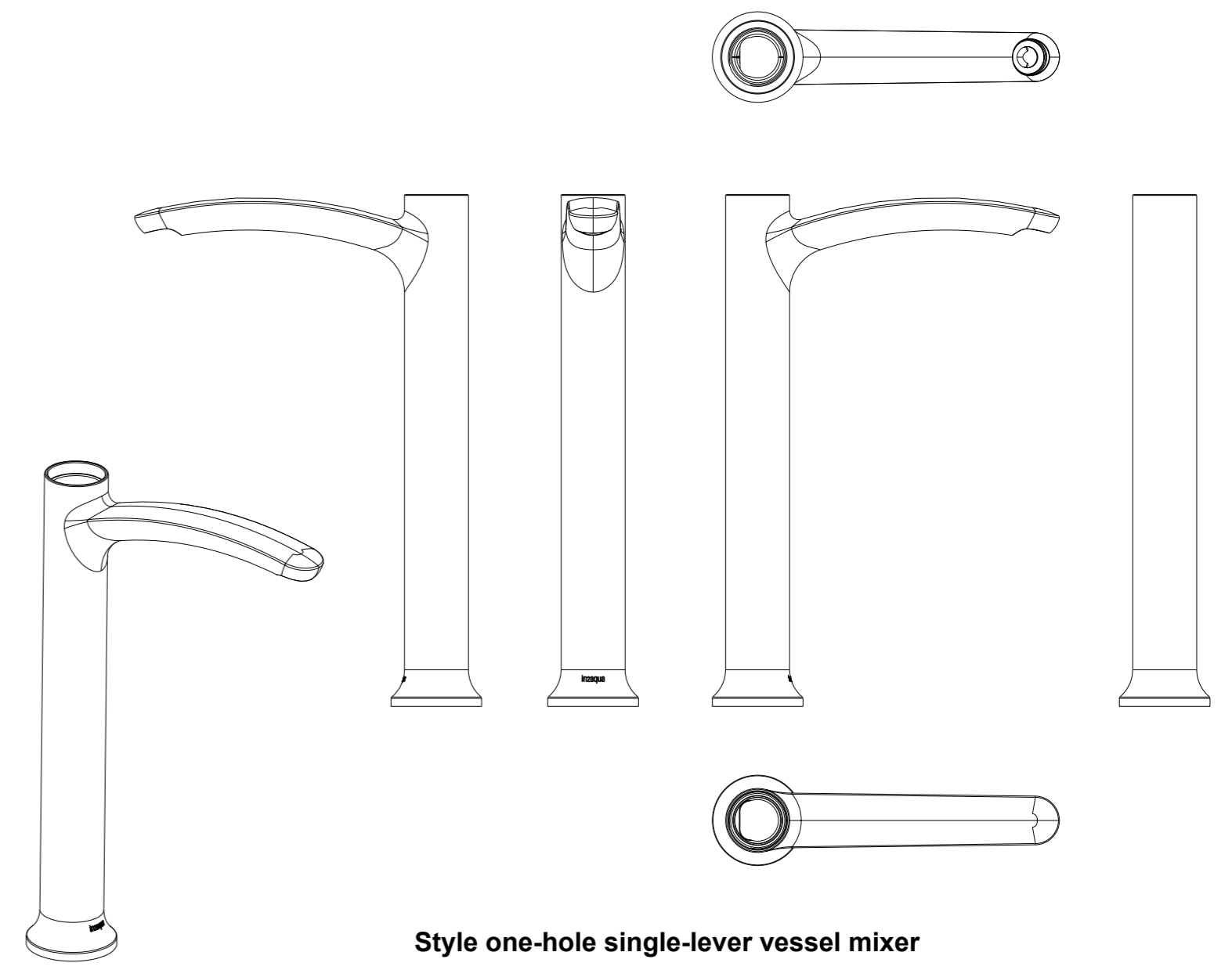

Style one-hole single-lever vessel mixer

Finish: chrome
Article number: 1028 1 00 2

Finish: brushed nickel
Article number: 1028 1 20 2